

CONTROLLING OF THE WORK OF THE HIGH CHARGED SI ENGINES WITH DIRECT INJECTION OF COMPRESSED NATURAL GAS

Władysław Mitianiec, Tomasz Ziolo, Marcin Kula

Cracow University of Technology
Al. Jana Pawla II 37, 31-864 Krakow, Poland
tel: +48 12 6283692, fax: +48 12 6283690
e-mail: wmitanie@usk.pk.edu.pl

Abstract

In the future many of spark ignition engines will be fuelled by the direct injection of the compressed natural gas. The spark ignition engines fuelled by CNG with lean and stratified charge in a low load mode require much more controlling of the air-fuel ratio than the diesel engines. The paper describes the total problems of the charging of SI engines particularly with direct injection of CNG. The control of the delivered mass of the fuel and the air in order to obtain the required mixture composition is given in mathematical way. The total control system of the engine with turbocharger, the CNG injection system and the model of gas flow in the exhaust and inlet ducts are shown in diagrams with wide work explanation. The paper concerns to the important problems of fuelling of "downsizing" new SI engines in order to fulfil the future exhaust emission requirements. The publication bases partially on the work which was done in the European project. The work was the first approach in order to determine the non-stationary work of the turbocharger in spark ignition engine.

Main conclusions of the work are: the pneumatic actuator in the waste-gate system is not suitable in the turbocharged spark ignition engines with direct CNG injection, the pressure and temperature before the turbine and in the inlet pipes fluctuates with not equal values of oscillations, the work was the first approach in order to determine the non-stationary work of the turbocharger in spark ignition engine.

Keywords: combustion engines, CNG, turbocharging

1. Introduction

Exhaust-gas turbochargers for passenger cars generally use single flow turbine housings. Presently standard practice favors regulating flow on the exhaust side, whereby a portion of the engine's exhaust gases is routed past the turbine (bypass) using the governing mechanism (waste-gate), which can be in the form of a valve or flap.

Till now generally the waste-gate is controlled by a pneumatic mechanism. In order to control of the air flow rate to the inlet system, particularly in SI engines, the system should have a pressure sensor or air flow rate sensor to give a signal to the waste-gate. The necessary control pressure in the upstream side of the turbine in order to regulate the mass flow rate of the exhaust gas should be assured by a control system. Sometimes it is possible to combine turbocharger and waste-gate in a single unit. Recently the control of the flow rate of exhaust gases through the turbine is assured by the PID controller.

2. Mathematical model of the turbocharger

The turbine shaft power can be determine from the isentropic expansion of the gas in the blades from the following formula [2]:

$$N_t = m_{ex} \cdot \eta_{t0} \cdot \frac{k_{ex}}{k_{ex} - 1} \cdot R_{ex} \cdot T_{ex} \cdot \left(1 - \left(\frac{p_{t2}}{p_{t1}} \right)^{\frac{k_{ex}-1}{k_{ex}}} \right), \quad (1)$$

where:

m_{ex} - mass flow rate of the exhaust gases through the turbine,

η_{t0} - turbine efficiency,

k_{ex} - ratio of specific heats,

T_{ex} - temperature of the exhaust gases,

p_{t2} - downstream turbine pressure,

p_{t1} - upstream turbine pressure,

R_{ex} - temperature of the exhaust gases.

Power consumed by the compressor has the similar form:

$$N_{cmp} = m_{cmp} \cdot \eta_{cmp0} \cdot \frac{k_{cmp}}{k_{cmp} - 1} \cdot R_{cmp} \cdot T_0 \cdot \left(\left(\frac{p_{c2}}{p_{c1}} \right)^{\frac{k_{cmp}-1}{k_{cmp}}} - 1 \right), \quad (2)$$

where index cmp is referenced to the compressed air and $c2$ and $c1$ are the index of the air after and before the compressor. Temperature T_0 is referenced to the ambient conditions.

In a steady state the power of the turbine and compressor are equal. For SI engine the mass flow rate of the compressor should assure the given relative air-fuel ratio λ . After comparison of the powers and taking into account the formula:

$$m_{ex} = m_{cmp} \frac{1 + \lambda L_a}{\lambda L_a}, \quad (3)$$

where L_a is the theoretical demand of the air to burn 1 kg of fuel.

The pressure before the turbine is calculated from the following equation:

$$p_{t1} = \frac{p_{t2}}{\left\{ 1 - \frac{C}{\tau} \left[\left(\frac{p_{c2}}{p_{c1}} \right)^{\frac{k_{cmp}-1}{k_{cmp}}} - 1 \right] \right\}^{\frac{k_{ex}}{k_{ex}-1}}}, \quad (4)$$

where constant C and τ are calculated from the dependences:

$$\tau = \eta_{t0} \eta_{cmp0} \frac{T_{ex}}{T_0}, \quad (5)$$

$$C = \frac{\lambda L_a}{1 + \lambda L_a} \frac{k_{cmp}}{k_{cmp} - 1} \frac{k_{ex} - 1}{k_{ex}}. \quad (6)$$

An increase of the charge pressure requires also a certain increase of the pressure and temperature of the exhaust gases before the turbine blades. This can also be done by an increase of the total efficiency of both machines.

3. Control of the mass flow rate

Amount of the delivered air from the compressor to the engine can be controlled in different ways: by waste-gate in the exhaust system, waste gate behind the compressor and by changeable nozzles flow in the turbine (changeable turbine geometry). In our case only the waste-gate in the exhaust system is considered. For this case the change of the pressure before the turbine is caused by the variable mass flow rate through the turbine. The valve in the waste-gate have to control the amount of the exhaust gases in the by-pass duct. The pneumatic device in the waste-gate system acts on the principle of the pressure difference (4) and does not take into account the required air-fuel ratio, turbocharger efficiency and thermal conditions influencing on the ratios of the specific heats (5)(6). The work of the SI engines particularly with the direct injection of CNG requires keeping $\lambda \gg 1$ in strictly narrow tolerance and such the pneumatic control of the waste-gate is not a suitable solution. Therefore the SI engine with turbocharger requires electronically control system taking into account the following measured parameters: pressures and mass flow rates in the inlet and exhaust systems and required λ (throttle position). The system is based on the PID controller (proportional-integral-differential). In nearest future the SI high-turbocharged engines with direct injection of CNG will be equipped with PID controller in waste-gate exhaust system. The work of the turbocharger in SI engine with maximum pressure above 150 bars occurs at high temperature and only ceramic blades or Al-Ti materials can be applied. In last years the control system of the turbocharger was developed by several manufactures and the diagram of one of working system is shown in Fig.1.

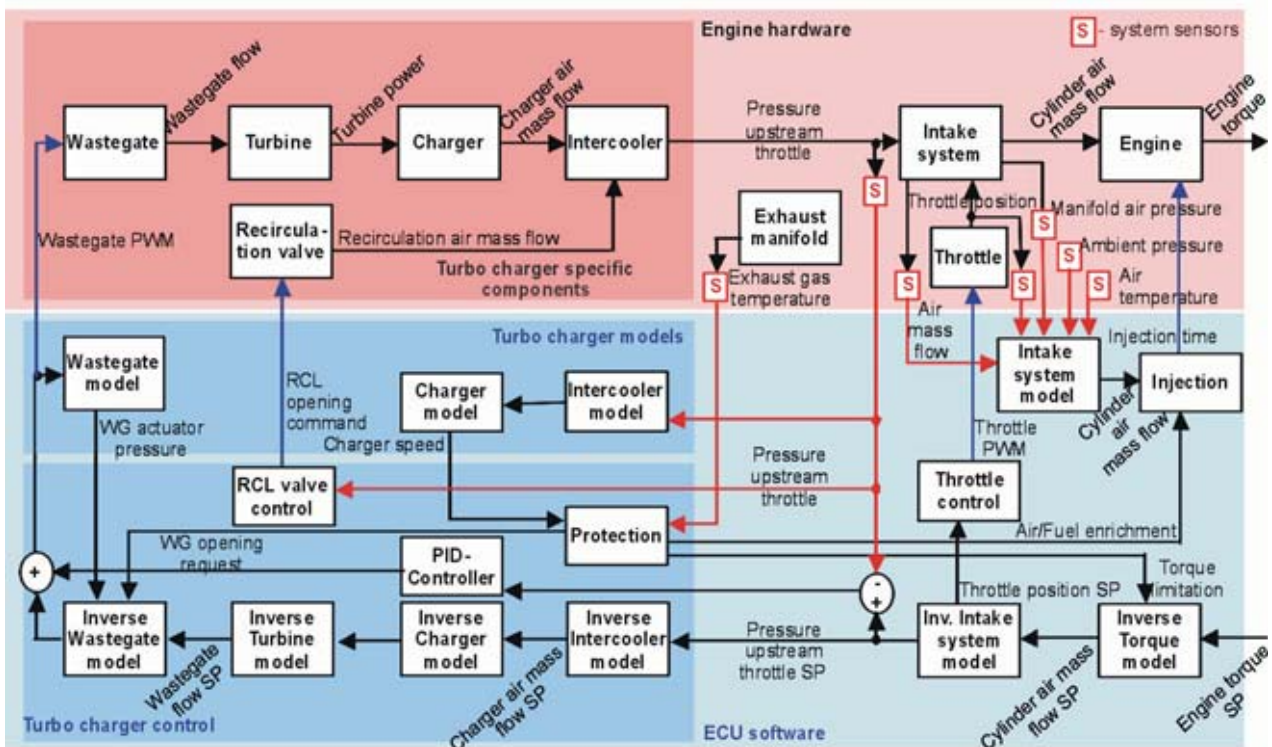

Fig. 1. The turbocharger and CNG direct injection control system

There are two ways of the parameter control in the prototyping: based on the thermodynamic model (mathematical dependences) and the other based on the control maps: fuel dose, mass flow rate, air-fuel ratio etc. in dependence of the rotational speed and throttle opening. The control system includes the following models: inverse torque, inverse intercooler, inverse charger, inverse turbine and inverse waste-gate. Besides those the system has the throttle, intercooler, charger,

turbine and waste-gate models. The control of the waste-gate occurs by use of PID controller by giving a corrected parameters before the waste-gate model.

4. Working of PID controller

Target boost pressure by controlling turbine waste-gate diameter or turbine rack position. The task of the PID controller is to achieve and maintain a target value of some sensible quantity from the system (also known as the "plant") by controlling some input to the plant. The sensed value from the plant is the input signal to the controller, and the output signal controller from the PID controller is used to "control" some actuatable device on the plant [4].

At every time step, the PID controller calculates the "error", which is defined as the difference between the specified reference signal and the input signal. The controller attempts to make its input signal equal reference signal by minimizing the error over time. The gains specified below are the parameters that determine the behavior of the controller. The proportional term produces a large output in response to a large error. The integral term produces a large output if the error has been accumulating over time. The derivative term gives a large output in response to a large change in error.

If a positive change in PID controller output will cause a positive change in the system output, the controller gains should be positive. For example, the gains should be positive if one wishes to control engine speed by adjusting fueling (more fuel will increase engine speed). If a positive change in PID controller output will cause a negative change in the system output, the controller gains should be negative. For example, the gains should be negative if one wishes to control boost pressure by adjusting waste-gate diameter (increasing the waste-gate opening will decrease the boost pressure). The following equations are solved in the PID controller:

$$\frac{dx_1}{dt} = u, \quad (7)$$

$$\frac{dx_2}{dt} = \frac{u - x_2}{\tau}, \quad (8)$$

$$y = \left(K_P + \frac{K_D}{\tau} \right) u + K_I x_1 - \frac{K_D}{\tau} x_2, \quad (9)$$

where K_P is the proportional gain, K_I is the integral gain, K_D is the derivative gain, τ is the derivative time constant, y is the controller output, u is the difference between the reference signal value and the input signal value, and x_1 and x_2 are the state variables. If the initial input signal value is known, one can control the initial output value through the state 1 initial value and state 2 initial value attributes.

5. Turbocharging control

For a high total efficiency the SI engine with direct injection of CNG works with lean mixtures ($\lambda=1,2 - 1,6$) in the stratified mode and with $\lambda \approx 1,05$ at full load. For checking the work of PID controller in turbocharged engine the simulation of the full engine system were carried out by use the special software GT-Power [4] based on the professional experience. The geometrical data of the engine were based on 4-cylinder 1,8 l capacity Daimler-Chrysler engine DC M271 DE18 with bore/stroke =82/85 mm. The calculation model of the whole engine system is shown in Appendix A.

The working of the turbocharger system is monitored by the boost monitor, which obtained the signals from the sensors and PID controller. The boost sensors measure the pressure and temperature behind the intercooler. On the other side the smooth and the sqrt are the certain

function set in the boost controller system in order to obtain very fast of the given value of the boost pressure. Boost monitor gives a signal to the actuator of the waste-gate valve to change the flow area in the by-pass pipe. The model of SAE turbine was used for calculations with given map of mass flow rate, rotational speed and pressure ratios. The turbine and compressor have the outer diameter equal 54,8 mm. The compressor efficiency map is shown in Fig.2, which was used in the simulation program in order to interpolate the mass flow rate and pressure ratio for a given rotational speed.

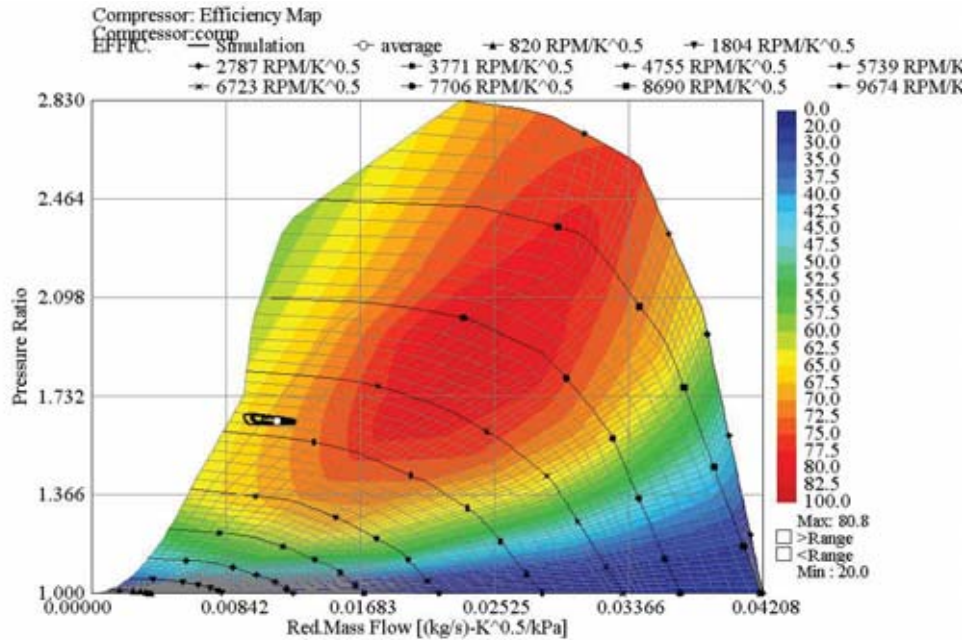

Fig. 2. Compressor map of SAE turbocharger

6. Calculation results

The engine was fuelled by direct injection of CNG at full load at rotational speed $n=3000$ rpm with fuel mass ratio in the cylinder corresponding to value 0,055. The injected fuel amounted 89 mg per all cylinders in one working cycle. The start of the fuel injection followed at 50 deg ATDC in the induction stroke. The required boost pressure ratio was assumed to be on the level 1,6. The task of the PID controller was to regulate the mass flow rate through the compressor by changing the rotational speed and thus the flow rate of the exhaust gases through the waste-gate. The chosen results of the engine parameters and flow in turbocharger system are presented in table 1.

Tab. 1. Calculation results of the engine and turbocharger

Parameter	Unit	Value
Max. cylinder pressure	bar	107,73
Mean indicated pressure	bar	17,26
Indicated efficiency η_i	%	42,6
Volumetric efficiency η_v	$-\eta_v$	1,272
Turbocharger rotational speed	rpm	104112
Compressor power N_{cmp}	kW	4,45
Turbine power N_{ex}	kW	4,48
Total compressor efficiency η_{cmp0}	%	68,2
Total turbine efficiency η_{t0}	%	61,8
WGT flow rate	m ³ /s	0,01043

The work of the PID controller is shown in Fig.3 during a certain time. After two seconds the PID controller stabilized the required value of the boost pressure ratio 1,6. The work of the PID controller is between some boundary values. This was done by giving some corrected factors in the PID controller described by the equations (7,8,9). The minimum and maximum outputs are the corrected values of the pressure ratios. The pressure before the intercooler oscillates above the required value of the boost pressure 1,6 bar and the variation of the pressure during one engine cycle in a relation to the first cylinder is shown in Fig.4. The maximum value of oscillation amounts 0,06 bar. The pressure oscillation forces also the oscillation of the temperature before and behind the intercooler in the same way. The maximum temperature of the air before the intercooler amounts 368 K and behind the intercooler it decreases to 328 K (40 K less). The influence of each cylinder on the pressure in the exhaust system and also on the upstream pressure in the turbine is connected with the length of the pipes and fluctuation of the pressure in the cylinders. Before each cylinder there is wave pressure motion, which causes the oscillation of the pressure. Variation of the pressure in the pipe before cylinder No 1 is shown in Fig.6.

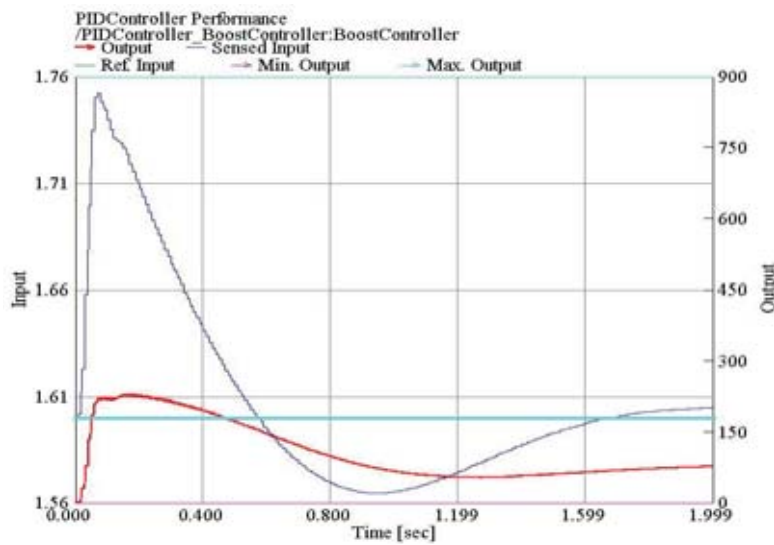

Fig. 3. Operation of the PID controller on the boost pressure ratio

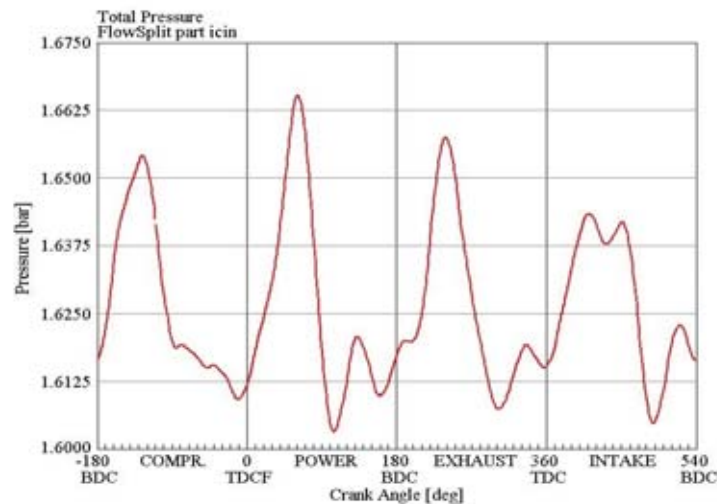

Fig. 4. Pressure before the intercooler

The fluctuation of the pressure inside the cylinders and configuration of the exhaust system take effect on the static pressure before the turbine (Fig.6). The maximum of the pressure before turbine amounts 1,8 bar and minimum 1,3 bar. The maximum temperature of the exhaust gases amounts 1100 K.

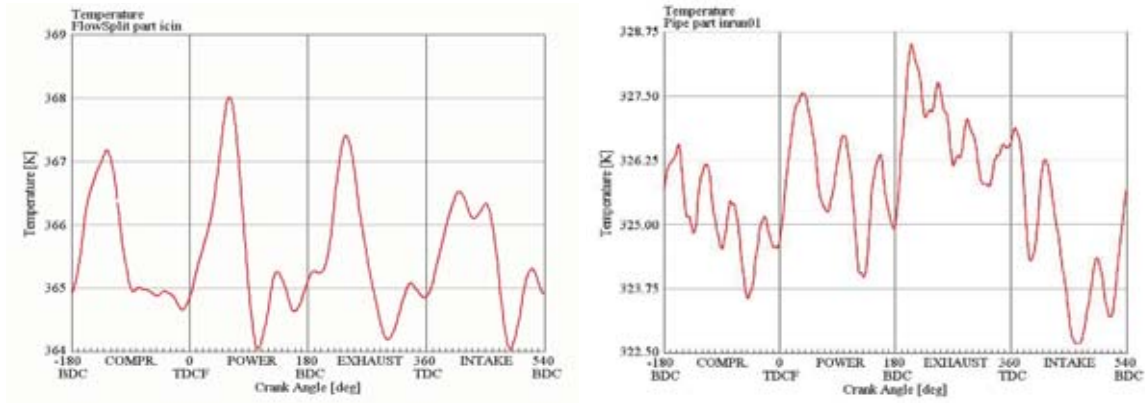

Fig. 5. Temperature before (left) and behind (right) the intercooler

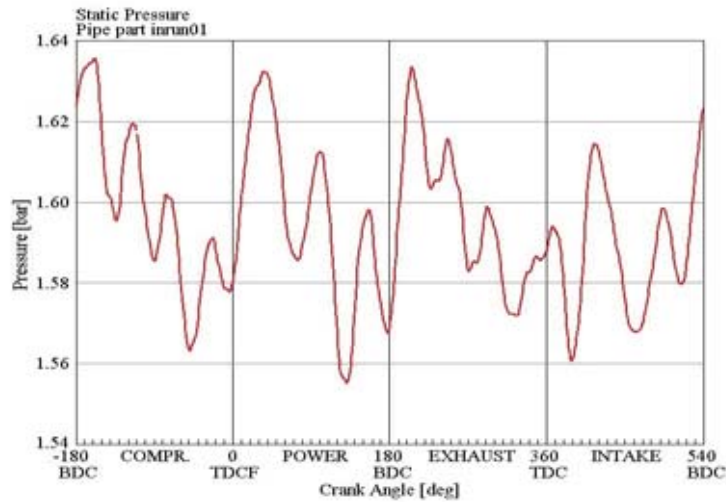

Fig. 6. Static pressure in the inlet duct before cylinder No 1

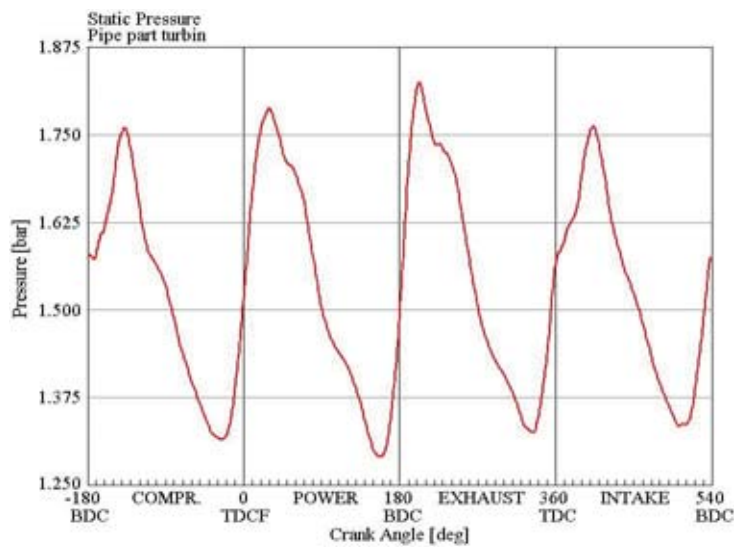

Fig. 6. Static pressure before turbine

7. Conclusions

1. The pneumatic actuator in the waste-gate system is not suitable in the turbocharged spark ignition engines with direct CNG injection.

2. Applying of the electronically controlled system with PID controller enables better regulation of the flow rate both in the turbine and the compressor.
3. The operation of the PID controller occurs with connection of the pressure and temperature sensors in the boost and turbine ducts.
4. In a unsteady operation the time of regulation depends on the correction factors given in the PID (boost controller) and in the carried out simulations the time amounted 2 s.
5. The pressure and temperature before the turbine and in the inlet pipes fluctuates with not equal values of oscillations.
6. The work was the first approach in order to determine the non-stationary work of the turbocharger in spark ignition engine.

8. Literature

- [1] Heywood, J. B., *Internal Combustion Engine Fundamentals*, Mc Graw-Hill, 1988.
- [2] Wajand, J.A., Wajand, J.T., *Tłokowe silniki spalinowe średnio- i szybkoobrotowe*, WNT, Warszawa, 1997.
- [3] Mitianiec, W., Jaroszewski, A., *Modele matematyczne procesów fizycznych w silnikach spalinowych małej mocy*, Ossolineum, Wrocław-Warszawa-Kraków, 1993.
- [4] *GT-POWER Tutorials, version 6.2*, Gamma Technologies, Westmont, USA, 2006.
- [5] *Automotive Handbook*, Robert Bosch GmbH, Stuttgart, 1996.
- [6] Wisłocki, K., *Systemy doładowania szybkoobrotowych silników spalinowych*, WKiŁ, Warszawa, 1998.
- [7] Arbogast, J., Cooper, D., Rice, R., *Model-Based Tuning Methods for PID Controllers*, Control Station Inc., Tolland USA, 2004.

Appendix

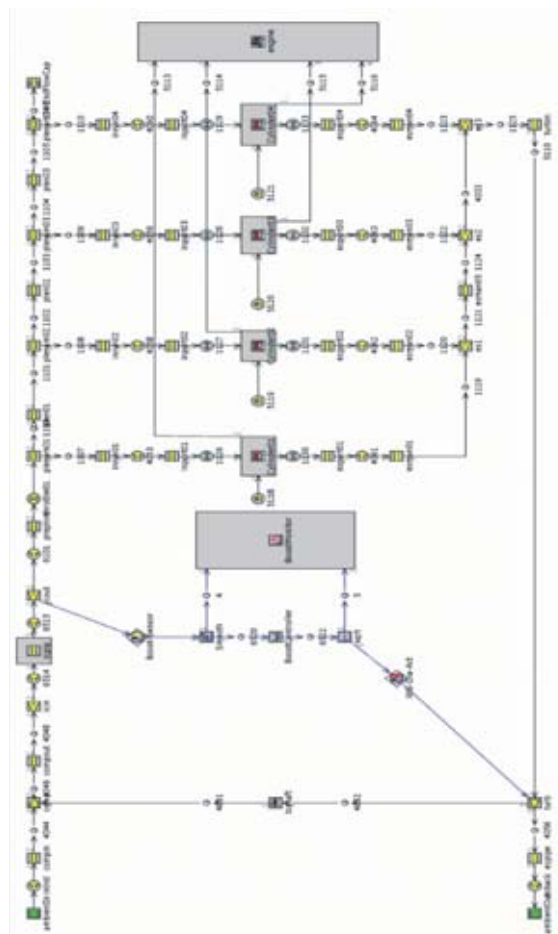

A. calculation model of the turbocharged SI engine with direct injection of CNG